

P-SBOX15

FAMILY

Silencer Box for Boothless Cinemas

P-SBOX15 is the second generation of lighter and more compact active enclosures, customized specifically for digital cinema projectors and remote monitoring.

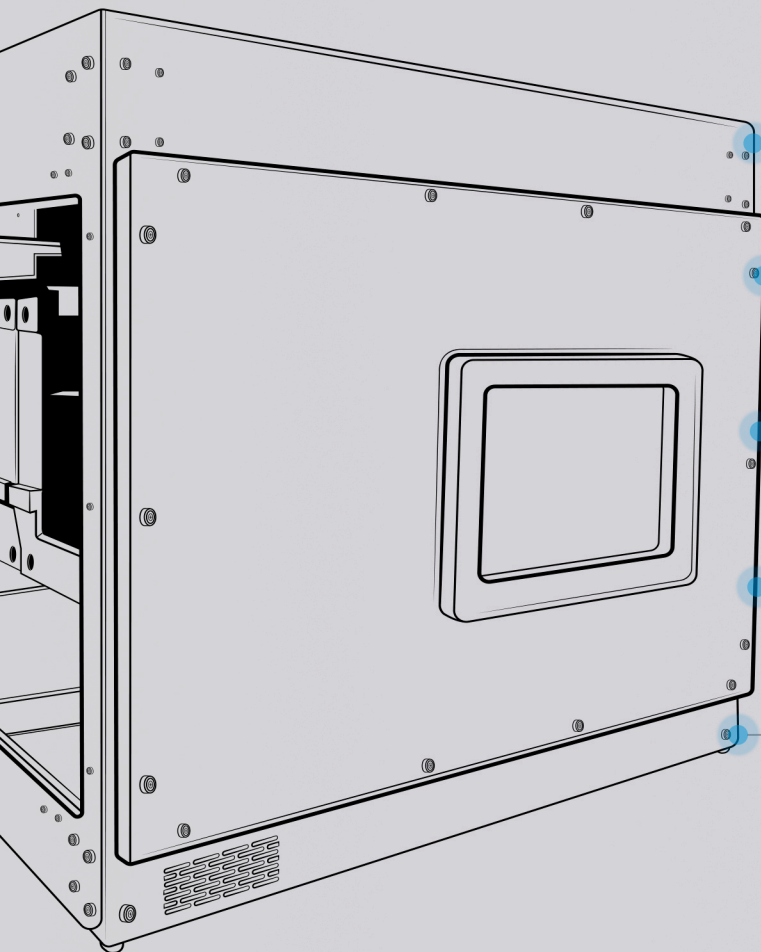
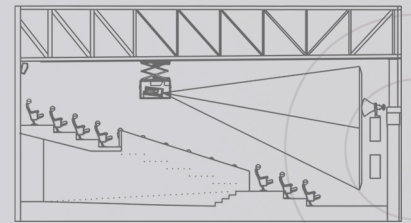

Protect digital projectors installed inside the auditorium.



Reduce projector noise to less than 40 dBA.



Keep the projector cool without the need for an extractor fan or exhaust duct.



Accommodate other digital cinema equipment, such as passive 3D systems, routers, converters, etc.



CinemaNext also offers two motorised lift options: the P-LIFTBOX allows you to install the P-WALLLIFT on the back wall of the auditorium, or suspend the P-SBOX15 from the ceiling.

Three models

to accommodate a wide range of DCI projectors:

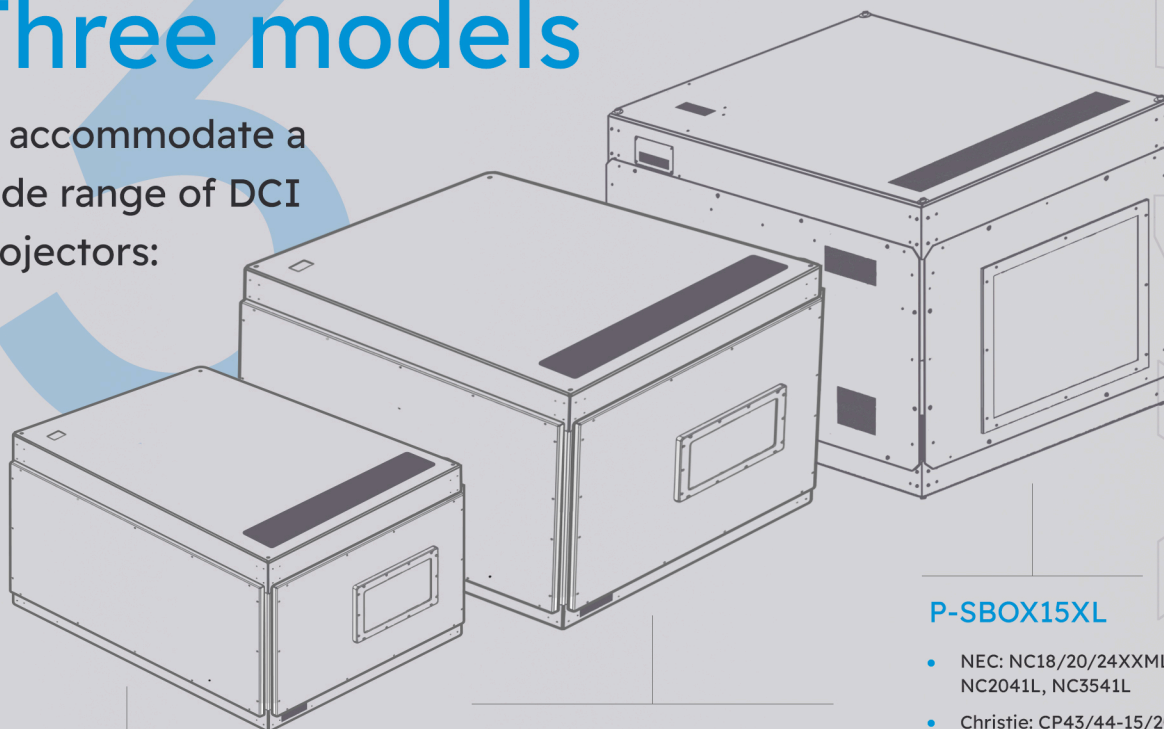

P-SBOX15 LOWER

- NEC: NC1201/02L, 1402L
- Barco: DP2K-8/10S, 8/10SLP
- Christie: CP23/24XXRGB

P-SBOX15

- NEC: NC900/1000C, NC1201/02L & NC1402L
- Barco: DP2K-6E, 8/10S, 12/15/20C, 8/10SLP, SP2KXX, SP4K-12/15/20/25C
- Christie: Solaria one+, CP2210/15, CP23/24XX RGB, CP23XX RGBe & 43/44-15/20/25 RGB, CP24xxRBe
- Panasonic: PTT-DZseries, PT-RQ y PT-RZ.

P-SBOX15XL

- NEC: NC18/20/24XXML, NC2041L, NC3541L
- Christie: CP43/44-15/20/25RGB

TECHNICAL SPECIFICATIONS

- **4 top eyebolts to hang it.**
- **Two kinds of motorized lifts available:** P-LIFTBOX (ceiling lift) and P-WALLLIFT.
- **Easily removable side panels** for easy maintenance of the projector.
- **Sound absorbing and insulating acoustic cladding** on all sides to acoustically isolate the projector from the outside.
- **Acoustic silencers**, specifically designed for all air inlets and outlets.
- **Sound suppressors**, specifically designed for all incoming and outgoing air.
- **Total noise** with a running projector: **<40dB @ 2m.**
- **Includes P-SBOXWATCHER card** to monitor and record temperature, humidity and fan operation, via ethernet.
- **Built-in internal cooling system.** No extraction duct required.
- **20A single-phase power shielding and double 220V power socket** to protect the digital projector and any other equipment housed internally.
- **Constructed from steel and aluminum**, it features a matt black electrostatic paint finish to avoid glare in the auditorium.
- Total weight: **P-SBOX15 LOWER**= 93 Kg. **P-SBOX15**= 98 Kg. **P-SBOX15XL**= 170 Kg.
- Dimensions: **P-SBOX15 LOWER**= 1350 x 1020 x 700 mm (53.14" x 40.15" x 27.55"). **P-SBOX15**= 1354 x 1020 x 850 mm (53.30" x 40.15" x 33.46"). **P-SBOX15XL**= 1639 x 997 x 1062 mm (64.50" x 39.25" x 41.81").
- **Space available for installation of a passive 3D system.** (Check compatibility between projectors and 3D systems.)

CinemaNext also offers two motorised lift options:

the P-LIFTBOX allows you to install the P-WALLLIFT on the back wall of the auditorium, or suspend the P-SBOX15 from the ceiling.

